

RECOMMENDED MOUNTING HOLE PATTERN FOR 1.60 [.063] THICK P.C. BOARD

- 1 POST TO WITHSTAND 13 NEWTONS (3 LBS.) MINIMUM AXIAL FORCE IN BOTH DIRECTIONS SHOWN WITHOUT DISLODGING.
- 2 TOLERANCES APPLY TO SOLDER SIDE OF BOARD.
- 3 MEASURED AT SURFACE -A-
- 4 PLASTIC FLASH PERMITTED IN THIS AREA.
- 5 PARTS COMPLY WITH AMP SOLDERABILITY SPEC. NO. 109-11-2.
- 6 ONE HOLE MAY BE UNDERSIZED 1.65/1.52 [.065/.060] DIA. FOR ASSEMBLY RETENTION DURING WAVE SOLDERING.
- 7 MATERIAL: HEADER-THERMOPLASTIC POLYESTER GLASS-FILLED 94V-0 (NATURAL) POST-COPPER ALLOY (SEE NOTES 13 & 14 FOR PLATING)
- 8 COORDINATE DIMENSION APPLIES FROM CENTER OF ACTUAL FEATURE.
- 9 PLASTIC BURRS CAUSED BY CUT-OFF TOOLING ARE PERMITTED WITHIN THE MAXIMUM TOLERANCE ENVELOPE.
- 10 POST TO BE MEASURED WHEN STRIP IS HELD FLAT.
- 11 POST MUST WITHSTAND TWO 90° BENDS AGAINST EXTRUSION WITHOUT BREAKING.
- 12 DIMENSION SHOULD BE 4.45 [.175] MIN WHEN MATING WITH A MTA .156 CONNECTOR ASSEMBLY OR A SL-.156 CONNECTOR ASSEMBLY.
- 13 PLATING: GOLD PLATE AREA, 0.00038 [.000015] MINIMUM, ALL SIDES, OVER NICKEL UNDERPLATE, 0.00127 [.000050] MINIMUM, ALL SIDES AND ENTIRE LENGTH OF POST.
- 14 PLATING: BRIGHT TIN/LEAD (93/7) PLATE AREA, 0.00381-0.00889 [.000150-.000350] THICK, ALL FOUR SIDES 4.45 [.175] MINIMUM FOR -2 THRU -24. MATTE TIN PLATE AREA 0.00381-0.00889 [.000150-.000350] THICK ALL FOUR SIDES, 4.45 [.175] FOR -32 THRU -54.

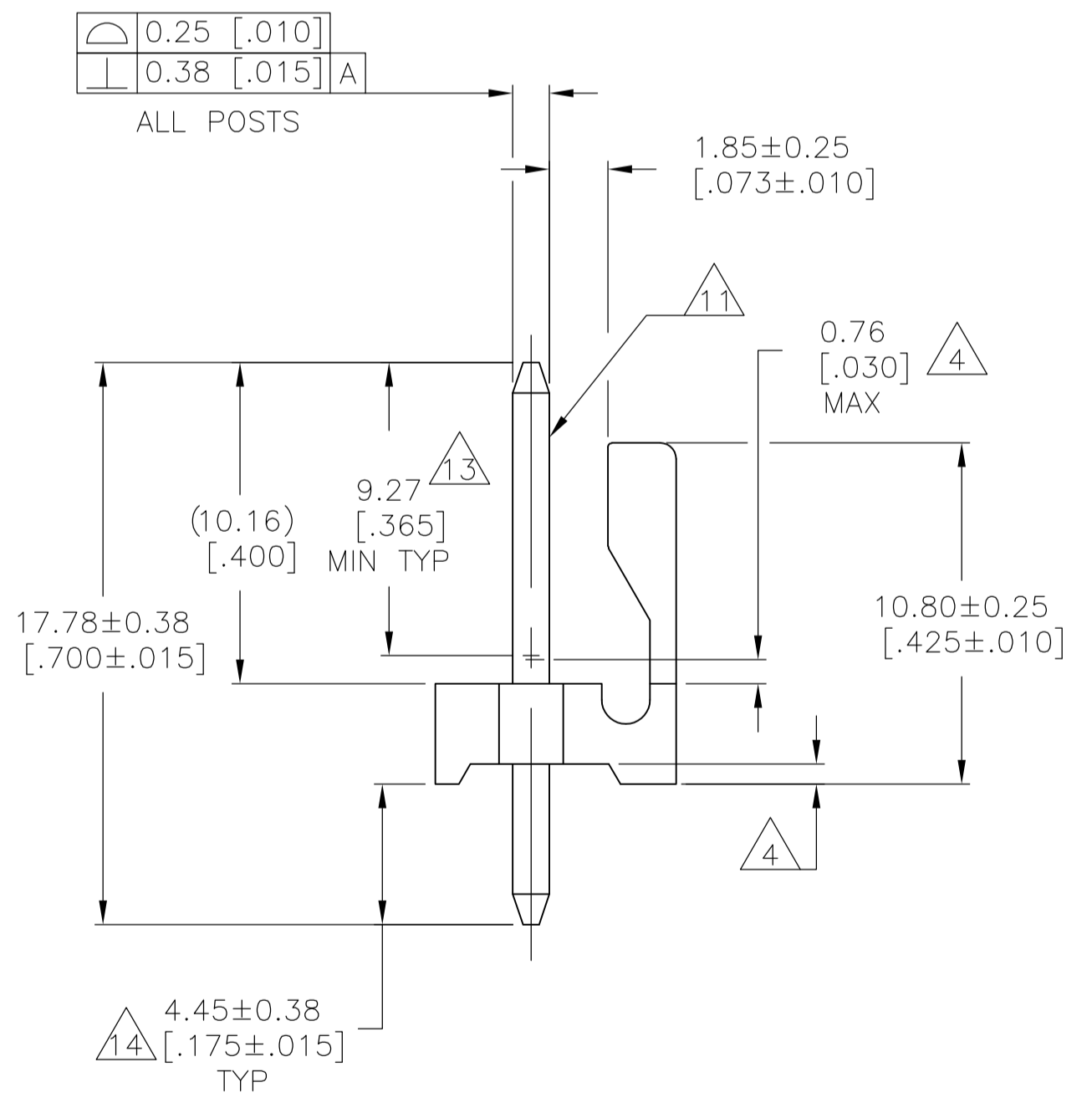
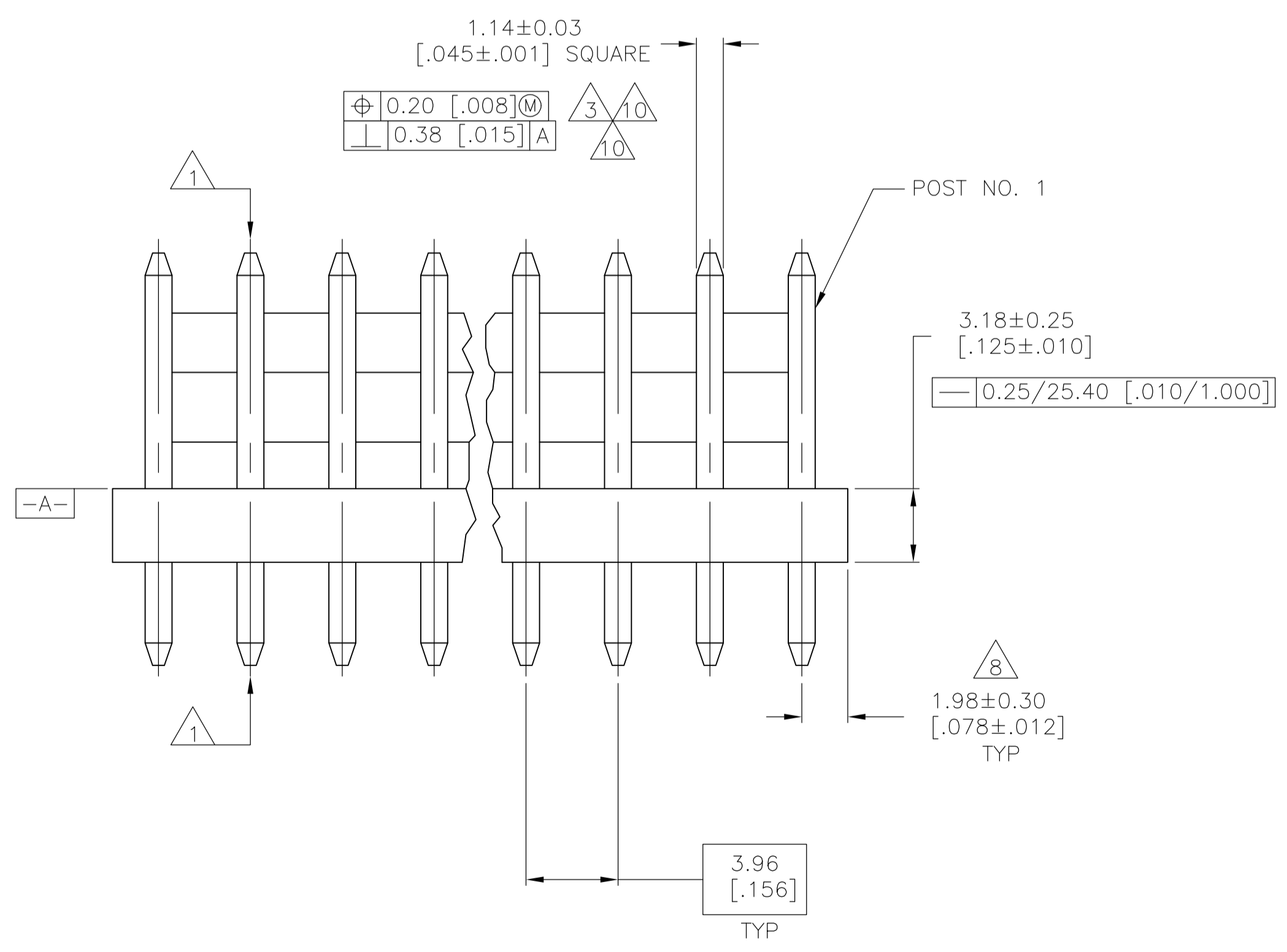

DIM (L)	NO.OF POSN	ASSEMBLY
95.10 [3.744]	24	5-644766-4
91.14 [3.588]	23	5-644766-3
87.17 [3.432]	22	5-644766-2
83.21 [3.276]	21	5-644766-1
79.25 [3.120]	20	5-644766-0
75.29 [2.964]	19	4-644766-9
71.32 [2.808]	18	4-644766-8
67.36 [2.652]	17	4-644766-7
63.40 [2.496]	16	4-644766-6
59.44 [2.340]	15	4-644766-5
55.47 [2.184]	14	4-644766-4
51.51 [2.028]	13	4-644766-3
47.55 [1.872]	12	4-644766-2
43.59 [1.716]	11	4-644766-1
39.62 [1.560]	10	4-644766-0
35.66 [1.404]	9	3-644766-9
31.70 [1.248]	8	3-644766-8
27.74 [1.092]	7	3-644766-7
23.77 [.936]	6	3-644766-6
19.81 [.780]	5	3-644766-5
15.85 [.624]	4	3-644766-4
11.89 [.468]	3	3-644766-3
7.92 [.312]	2	3-644766-2

DIM (L)	NO.OF POSN	ASSEMBLY
95.10 [3.744]	24	2-644766-4
91.14 [3.588]	23	2-644766-3
87.17 [3.432]	22	2-644766-2
83.21 [3.276]	21	2-644766-1
79.25 [3.120]	20	2-644766-0
75.29 [2.964]	19	1-644766-9
71.32 [2.808]	18	1-644766-8
67.36 [2.652]	17	1-644766-7
63.40 [2.496]	16	1-644766-6
59.44 [2.340]	15	1-644766-5
55.47 [2.184]	14	1-644766-4
51.51 [2.028]	13	1-644766-3
47.55 [1.872]	12	1-644766-2
43.59 [1.716]	11	1-644766-1
39.62 [1.560]	10	1-644766-0
35.66 [1.404]	9	644766-9
31.70 [1.248]	8	644766-8
27.74 [1.092]	7	644766-7
23.77 [.936]	6	644766-6
19.81 [.780]	5	644766-5
15.85 [.624]	4	644766-4
11.89 [.468]	3	644766-3
7.92 [.312]	2	644766-2

METRIC

THIS DRAWING IS A CONTROLLED DOCUMENT.

DIMENSIONS: mm [INCHES]	TOLERANCES UNLESS OTHERWISE SPECIFIED:	DIN S: HOOVER 07NOV02	CMK: D. ROSSI 07NOV02	APVD: D. ROSSI 07NOV02	NAME: D. ROSSI
0 PLC ± -	1 PLC ± -	2 PLC ± 0.13 [.005]	3 PLC ± -	4 PLC ± -	ANGLES ± -
MATERIAL: 7	FINISH: 8	SIZE: A1	CAGE CODE: 00779	DRAWING NO: 644766	RESTRICTED TO: -
CUSTOMER DRAWING		SCALE: 5:1	SHEET: 1 of 1	REV: E	

Tyco Electronics Corporation
 Harrisburg, PA 17105-3608

MTA-.156 HEADER ASSEMBLY, FRICTION LOCK, STRAIGHT, .045 SQUARE POST, .000015 GOLD, SPECIAL